

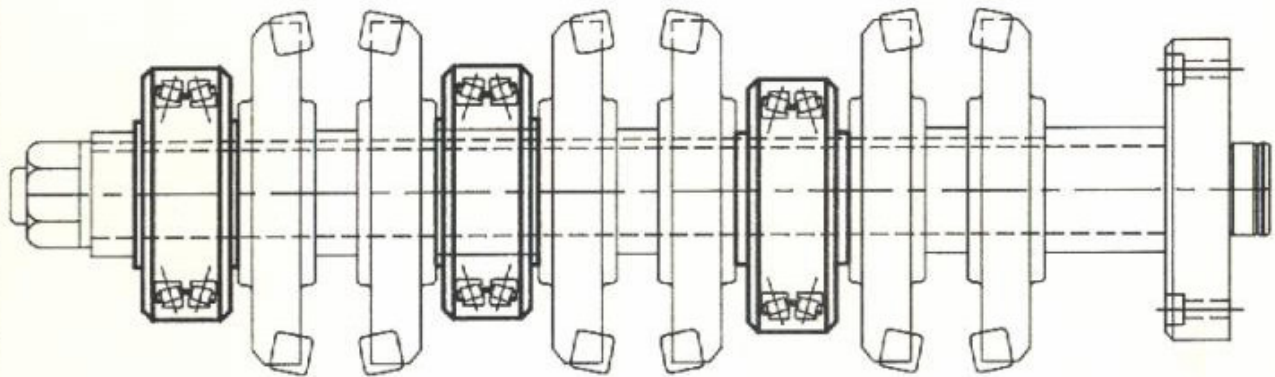

GATCO, INC.

DATA
SHEET
1006

PRECISION GANG MILLING ARBOR BUSHINGS



TYPICAL GANG MILLING ARBOR BUSHING

BENEFITS

- ELIMINATES CHATTER AND VIBRATION
- HIGH LOAD CARRYING CAPABILITIES
- HELPS DAMPEN AND EVENLY DISTRIBUTES CUTTING FORCES
- ELIMINATES EXCESSIVE MOUNTING CLEARANCES

FEATURES

- COMPACT DESIGN TO FIT WITHIN TIGHT SPACE CONSTRAINTS
- SEALED AGAINST CONTAMINATION
- STANDARD SIZES AVAILABLE TO FIT YOUR APPLICATION
- CARTRIDGE DESIGN FOR EASY INSTALLATION

■ CALL OR FAX WITH YOUR DIMENSIONAL REQUIREMENTS ■

GATCO, INC. 42330 E. ANN ARBOR RD., PLYMOUTH, MI 48170 PHONE (734) 453-2295 FAX (734) 453-2310

PRECISION GANG MILLING ARBOR BUSHINGS

ROTARY BUSHING DESIGN FAX

SIMPLY PHOTOCOPY THIS FORM, FILL IN THE DIMENSIONS
REQUIRED AND FAX TO US FOR IMMEDIATE DESIGN AND QUOTATION

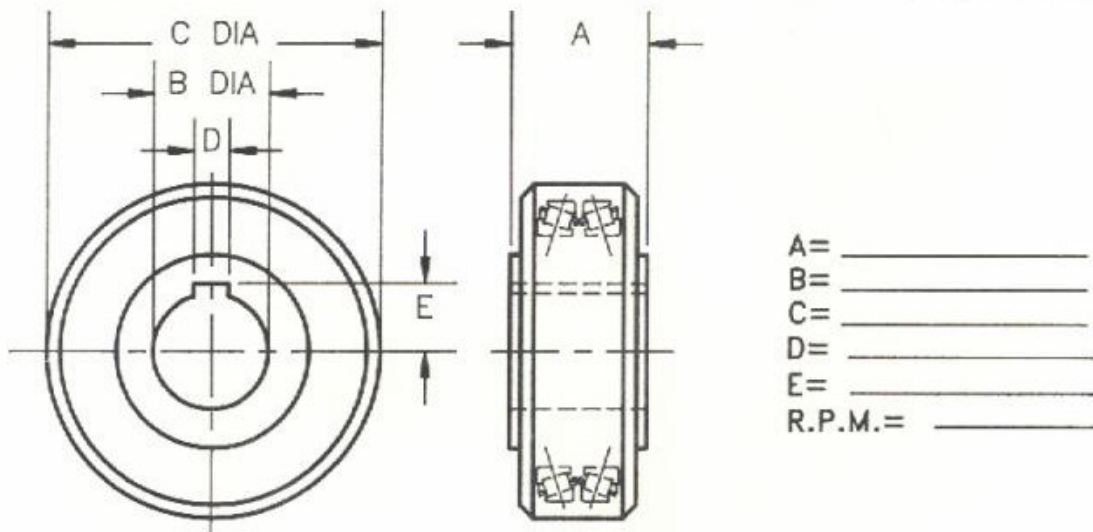

A= _____
B= _____
C= _____
D= _____
E= _____
R.P.M.= _____

COMPANY NAME: _____ PHONE: _____
ADDRESS: _____ FAX NO.: _____
CONTACT NAME: _____ DATE: _____
QUANTITY: _____ DELIVERY REQD. _____

Gatco's gang milling arbor bushings (also known as "Pancake Bushings" because of their compact design) are used for milling applications where space is limited and cataloged bushings will not fit. A typical application would be to mill engine block bulkheads. They are superior to bearings which are commonly designed on arbors based strictly on size consideration alone. Gang milling arbor bushings are designed specifically to provide maximum load carrying capacity while fitting within the limited space normally allowed for in these operations; particularly the width limitation. Further, they eliminate the need for spacers and additional parts because they mount directly on the arbor and when their overall length is held can act as a spacer. Contact Gatco for gang milling arbor sizes or fill in the Fax page above and send to us for immediate design evaluation.



GATCO, INC.

42330 E. ANN ARBOR ROAD
PLYMOUTH, MI 48170 USA
PHONE (734) 453-2295
FAX (734) 453-2310