

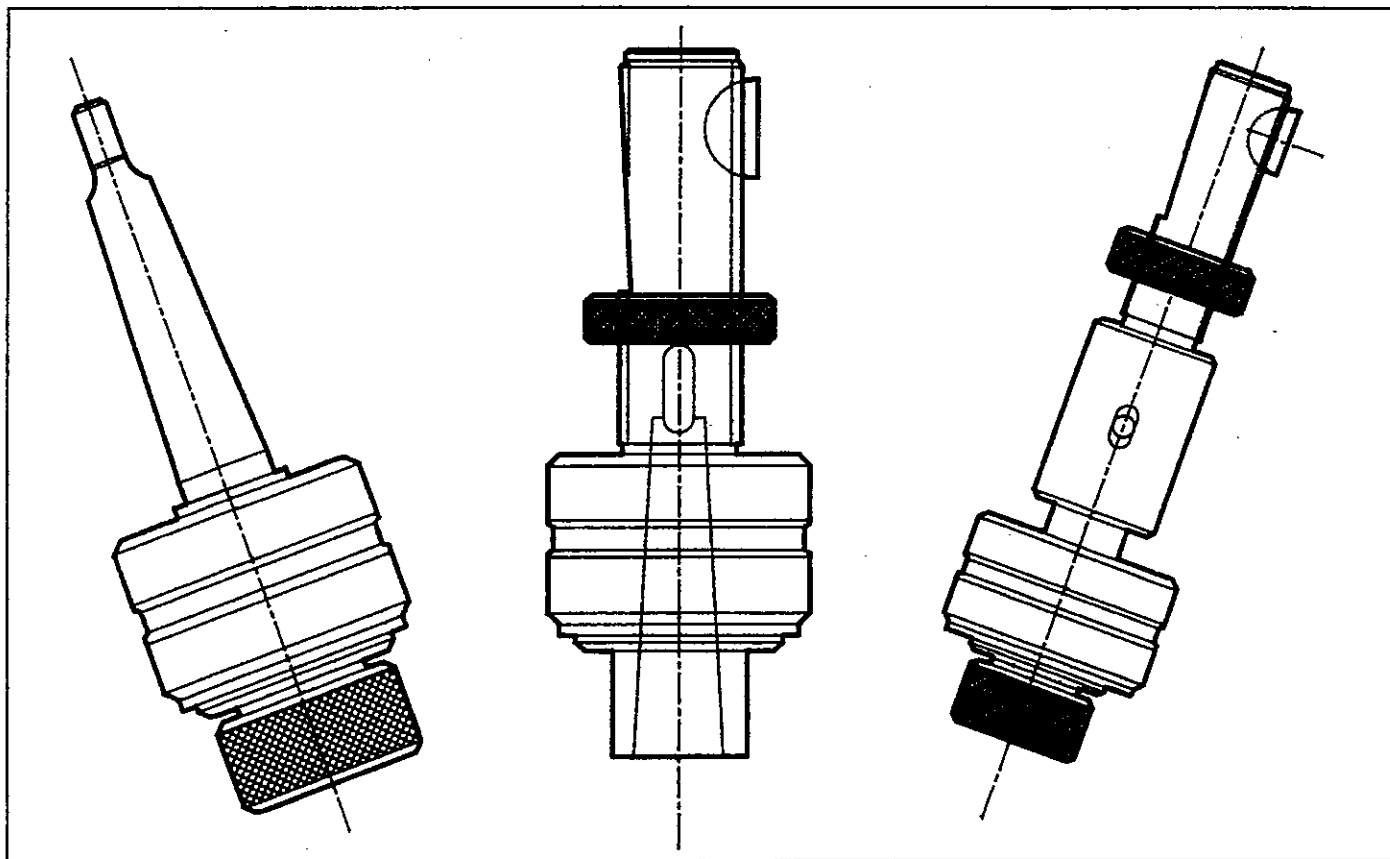

# GATCO, INC.

DATA  
SHEET  
1005

## *PRECISION FLOATING TOOLHOLDERS*



### BENEFITS

- ELIMINATES OVERSIZED, OUT-OF ROUND AND BELLMOUTHED HOLES
- COMPENSATES FOR MISALIGNMENT BETWEEN THE SPINDLE AND THE PART
- PREVENTS TAP/TOOL BREAKAGE

### FEATURES

- ANTI-FRICTION PARALLEL FLOAT UP TO .03 FROM CENTERLINE
- HIGH TORQUE AND AXIAL THRUST CAPABILITY WITH SELF CENTERING MECHANISM
- ALL HOLDERS OFFER PRECISION AND QUALITY WORKMANSHIP

■ CALL OR FAX WITH YOUR SPECIAL DESIGN REQUIREMENTS ■

GATCO, INC. 42330 ANN ARBOR ROAD, PLYMOUTH, MI 48170 (734) 453-2295 FAX (734) 453-2310

# PRECISION FLOATING TOOLHOLDERS

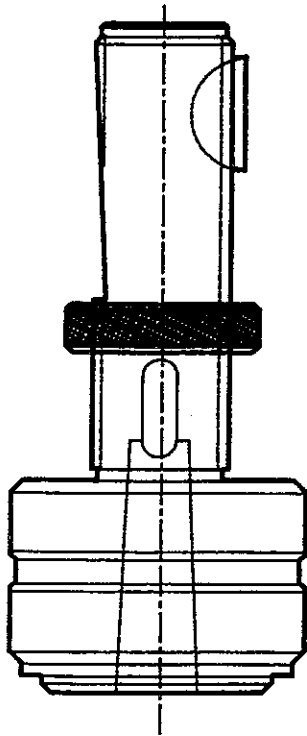

## FLOATING TOOLHOLDER STYLES AVAILABLE

- COMPRESSION/TENSION
- COLLET-TYPE
- FLANGE-TYPE ( LINE BORING )
- MORSE TAPER
- STRAIGHT HOLE
- QUICK-CHANGE COLLET
- QUICK-CHANGE MORSE TAPER
- QUICK-CHANGE TAP
- COOLANT-INDUCED
- ANTI-FRICTION ROTARY TYPE
- STANDARDS AND SPECIALS

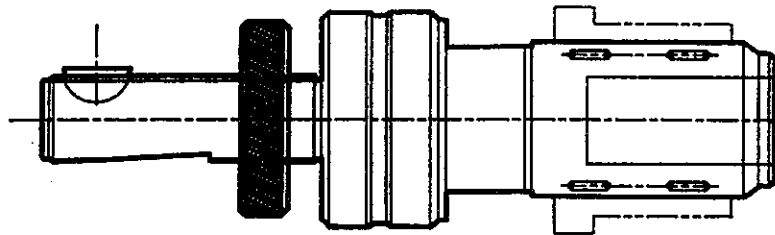

## ANTI-FRICTION FLOATING ROTARY TOOLHOLDER

GATCO, INC. IS THE ONLY MANUFACTURER OF TOOLHOLDERS TO OFFER ANTI-FRICTION ROTARY FLOATING TOOLHOLDERS. THESE HOLDERS INCORPORATE A BEARING ASSEMBLY MOUNTED ON THE TOOLHOLDER NOSE WHICH PILOTS IN A SUPPORT BUSHING DURING OPERATION. THIS UNIQUE DESIGN ALLOWS FOR TIGHTER TOLERANCES AND MORE ACCURATE LOCATION OF THE CUTTING TOOL DURING MACHINING. CONTACT GATCO'S SALES DEPARTMENT OR FAX A SKETCH OF YOUR NEEDS.

■ WE MAKE THE HOLDERS NO ONE ELSE WILL ■



# GATCO, INC.

42330 ANN ARBOR ROAD  
PLYMOUTH, MI 48170  
PHONE (734) 453-2295  
FAX (734) 453-2310